

# TECHNICAL BASICS

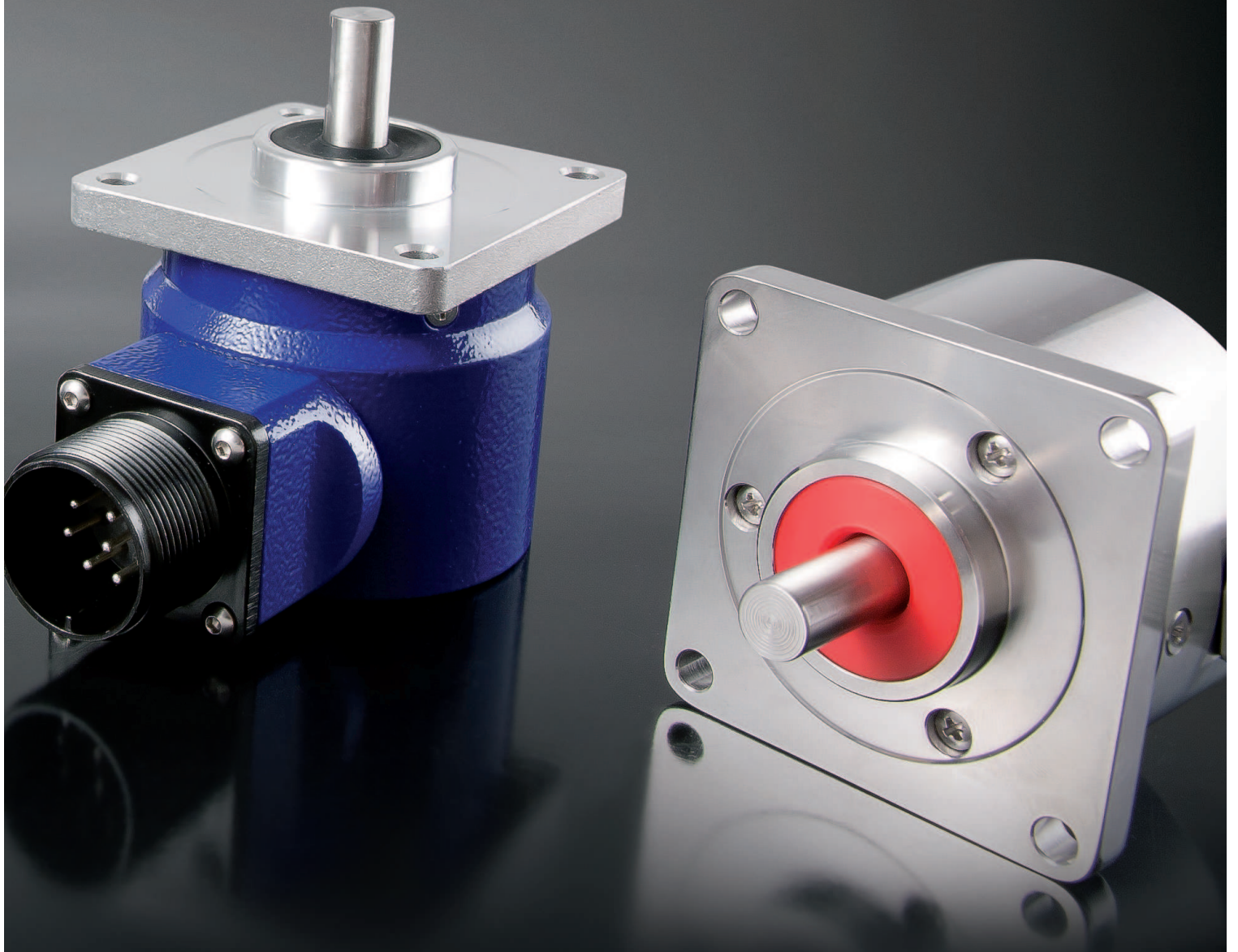

### WHAT IS AN ENCODER ?

The encoder is a transducer of position and speed which converts the angular or linear motion of a shaft (or axle) into a series of electrical digital pulses.

These electrical pulses are employed to control the motion of the mechanical shaft (that has generated them).

The encoder is composed by:

- **Mechanical interface**
- **Code wheel (or magnetic actuator or linear scale)**
- **Optoelectronic receiver (or magnetic sensor)**
- **Electrical interface**

Main technologies used in encoders to detect the signals are:

- **Photoelectrical or optical scanning (rotary or linear)**
- **Magnetic field variations (rotary or linear)**
- **Potentiometer (rotary or linear)**
- **Magnetostrictive effect (linear)**
- **Energy Harvesting Effect (rotary)**

Main applications of rotary and linear transducers are: machine-tools, material processing machinery, robots, motor feedback systems, measure and motion control devices.

### MECHANICAL INTERFACE

The mechanical interface consists in all those components that allow the coupling of the encoder to the machine or device of application, which are:

1. An **axle**, connected to the shaft of the machine in rotation, designed in accordance to the type of fixing: **solid** or **blind/through hollow shaft**;
2. A **flange**, which fixes and adjusts the encoder to its support;

3. An **housing (or body)**, which contains and protects the disc and the electronic components.

Elastic couplings can also be used to adapt the fixing between the motor shaft and the encoder.

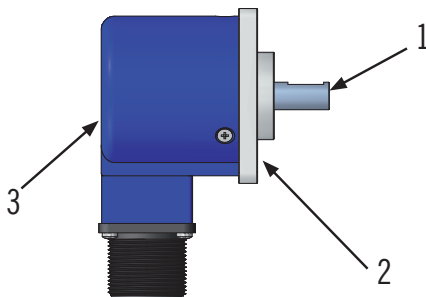

Some examples of encoders' mounting

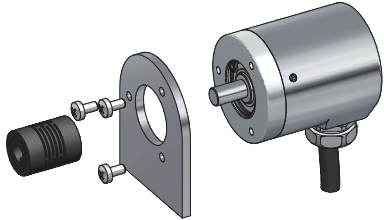

Solid shaft rotary encoder mounted by a fixing flange and the elastic coupling.

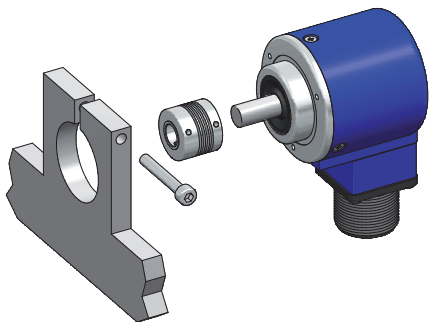

Solid shaft rotary encoder mounted by a clamping fixing.

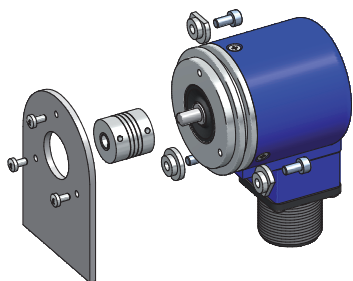

Solid shaft rotary encoder mounted by a fixing flange (or by fixing clamps) and the elastic coupling.

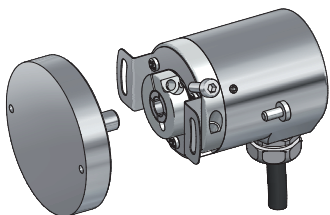

Blind hollow shaft rotary encoder mounted by a stator coupling with collar clamping shaft fixing.

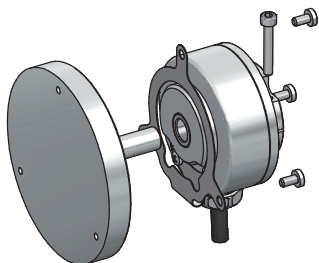

Through hollow shaft encoder with a rear collar clamping shaft fixing.

### ENCODER CODE WHEEL (OR MAGNETIC / LINEAR SCALE)

The encoder code wheel (or disc) defines the transmission code of pulses; it is formed by a support made of plastic, glass or metallic material, on which is engraved a pattern of alternated clear (transparent) and opaque seg-

ments. On linear scales this pattern is replaced by a stationary opaque strip. With magnetic sensing codewheel or linear scale is substituted by a magnetic (north / south) pattern.

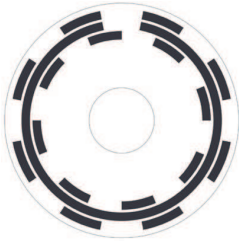

Example of codewheel

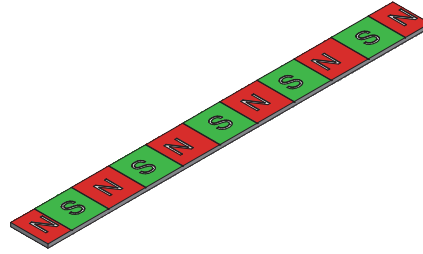

Example of magnetic linear tape

### ENCODER OPTOELECTRONIC RECEIVER (OR MAGNETIC SENSOR)

The optoelectronic receiver is made by an array of sensor (photodiodes or phototransistors) which is illuminated by an infrared light source (IR LED). Between the receiver and the LED there's the graduated codewheel. The light projects the disk image on the receivers surface which are covered by a grating called reticle having the same disk steps. The receivers trasduce

the occurring light variations caused by the disk shifting and convert them into their corresponding electrical variations. In magnetic encoders system is made by a rotating actuator with a magnet and the magnetic sensor convert magnetic field variation into electrical signals.

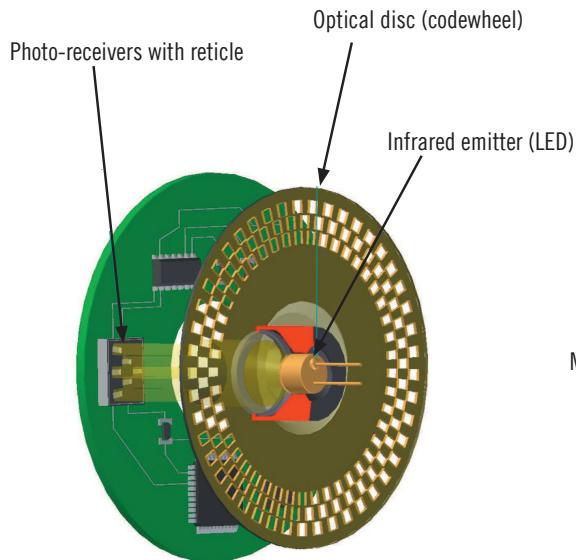

Example of optoelectronic sensor

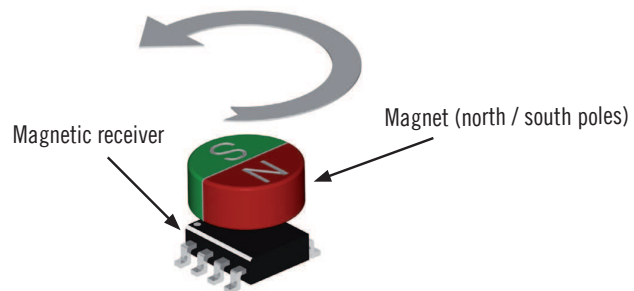

Example of magnetic sensor

## Electrical interface

The electrical interface is the way the encoder communicates data to a receiver. Electrical signals (can be digital or analogue) are transmitted through the encoder cable to an intelligent device such as interface board, PLC, etc

Electronics interface depends on the encoder type, incremental or absolute.

Interfaces on incremental encoders are:

- **NPN**
- **NPN Open collector**
- **Push pull**
- **Line driver**

interfaces on absolute encoders are:

- **Analogue (voltage or current )**
- **Bit parallel (NPN / NPN Open collector / PNP / PNP Open collector / Push pull)**
- **Serial transmission (Serial Synchronous Interface SSI)**
- **Fieldbus (Profibus or Profinet)**

## PHOTOELECTRIC OR OPTICAL SCANNING (ROTARY OR LINEAR)

There are two ways on optical scanning to build an optical system: transmissive or reflective.

In the transmissive optical encoder, the scan system is based on the rotation of a graduated disc - or code wheel - patterned with alternating opaque and clear (transparent) segments; the code wheel is illuminated by an infrared light source positioned perpendicularly to the sensor.

The disc beams its image on the surface of several receivers, opportunely masked by another grid (called "reticle") with the same pitch as the other. The receivers have the task to sense the variations of light that take place during the rotation of the disc, converting them into corresponding electric pulses. In linear transducers the operating principle is similar, with the difference that the motion is detected on a linear reading system.

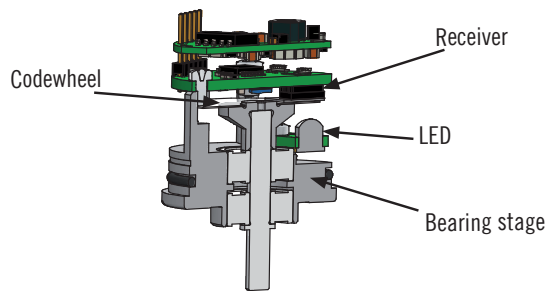

Example of transmissive encoder

The reflective optical system is also based on the photoelectric scanning of a code wheel, but in this type of technology the light source and the receiver are in the same surface mount package: the light source illuminates the code wheel formed by darker segments alternated with reflective ones, where the light is reflected and detected by the sensor (receiver), which will

transform the variations in corresponding pulses, as per the transmissive system. This type of reading allows reducing the size of the device while maintaining its performances; it's an ideal solution for those applications that require miniaturized encoders with a high resolution.

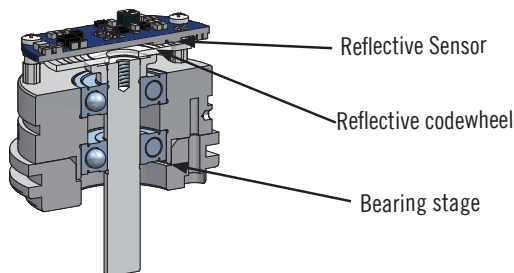

Example of reflective encoder

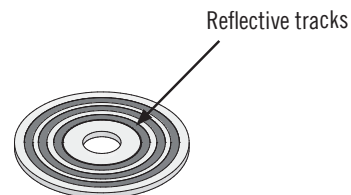

Example of reflective code wheel

## MAGNETIC SENSING (ROTARY OR LINEAR)

Magnetic encoders employ a signal detection system based on the variation of the magnetic flux generated by a magnet (one or more pole pairs) placed in rotation in front of a sensor, usually fixed to the encoder's shaft. The variation of the magnetic field is sampled by the sensor and converted into an electric pulse, which determines the position; the magnetic technology could be of two types: on axis or off axis.

The main benefit of the magnetic technology is the absence of contact in the detection system, which helps preventing the wear and it's therefore quite convenient in terms of cost, since it doesn't require maintenance and has a potentially infinite durability.

Magnetic encoders are particularly suitable for heavy duty applications that require high robustness, speed and a wide range of operating temperature, while ensuring, at the same time, an excellent reliability in the generation of signals.

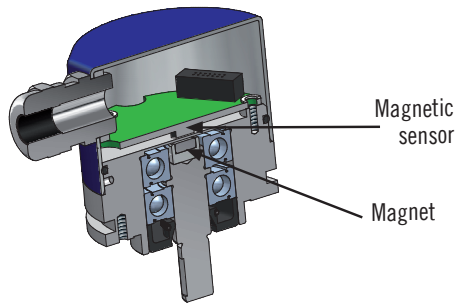

Magnetic rotary encoder

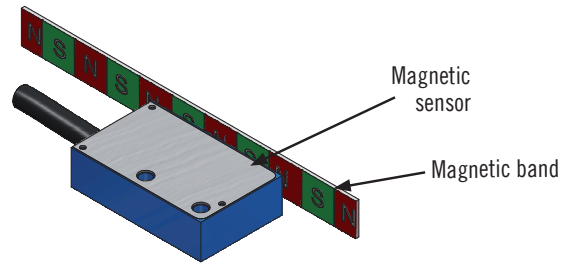

Magnetic incremental linear encoder

## ENERGY HARVESTING (ROTARY)

On the multiturn side, the multiturn counting is enabled utilizing energy-harvesting technology.

When the shaft is rotating, the magnet mounted on the shaft moves in tandem. The energy-harvesting coil module cuts the moving magnet field, and generates energy as a result. The beauty of the energy-

harvesting effect is that the same amount of energy is generated independently of the rotation speed. The generated energy is sufficient to power up the revolution tracking circuitry. Therefore, no miscounts occur even in the absence of external power supply. It can replace traditional gear technology due to absence of wear (no contact technology).

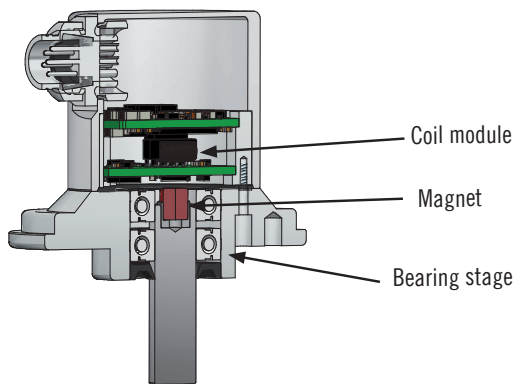

Energy Harvesting engine

## POTENTIOMETRIC SENSING (ROTARY OR LINEAR)

This type of linear / rotary transducer is formed by a wire or a metal layer, wound up in a non-conductor support, and by a movable contact that shifts along the conductor.

The operating principle is based on the change in resistance of an electric circuit, caused by the displacement of the object of which the position must be determined.

Potentiometers are particularly suitable for the employment in thermo-plastic, wood, marble, iron and steel processing machinery and for any application that requires position and motion absolute measurement.

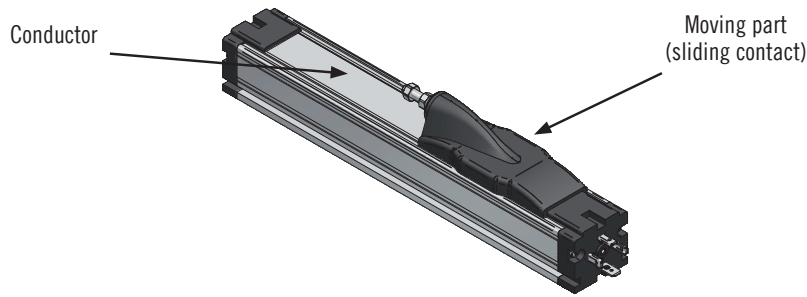

## MAGNETOSTRICTIVE SENSING (LINEAR)

Magnetostrictive transducers are based on the magnetostriction principle for which certain materials expand and contract when they are put into an alternate magnetic field.

Those two magnetic fields are generated from the moving magnet and from the current pulse inside the tube of the transducer.

This interaction creates a strain pulse which travels inside the tube until it is detected by the electronics.

The absolute position is calculated by measure the time of the strain pulse compared to the current pulse who generate it.

The key factor of this technology is the absence of any electric contact on the slider, which makes the device highly resistant to wear and tear while ensuring great performances in speed and precision.

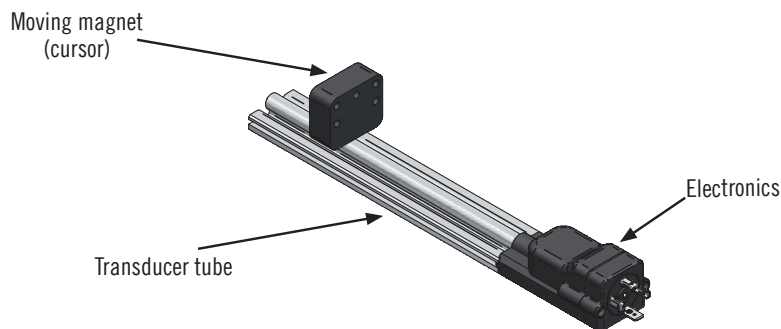

The incremental encoder is so defined since it tracks the increase (variation) in relation to a position taken as a reference point, independently from the direction of rotation. The incremental encoder senses rotation, speed and acceleration by counting the number of pulses sent by the output circuit, although the zero point of the machine must be reset at every new start.

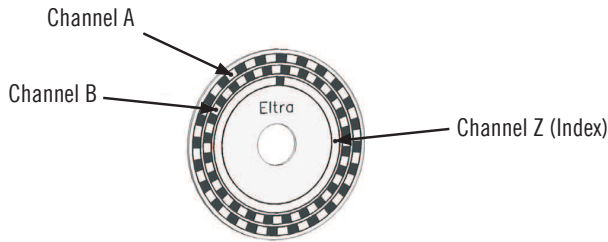

Example of 3 channels incremental encoder codewheel

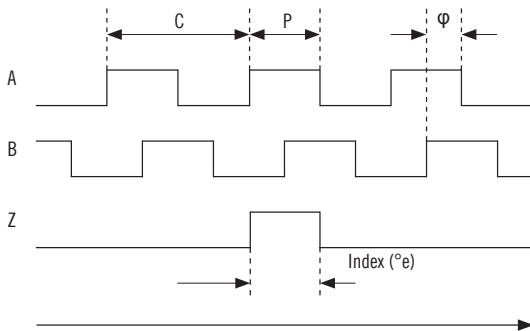

Incremental encoder output signals

A leads B clockwise rotation (shaft view)



One Cycle: 360 electrical degrees (°e).

Cycle Error ( $\Delta C$ ): an indication of cycle uniformity. The difference between an observed shaft angle which gives rise to one electrical cycle, and the nominal angular increment of 1/N of a revolution.

Pulse Width (P): the number of electrical degrees that an output is high during 1 cycle. This value is nominally 50 % (or 180°e).

Pulse Width Error ( $\Delta P$ ): the deviation, in electrical degrees, of the pulse width from its ideal value. Typical value is max  $\pm 10\%$  on optical encoders or  $\pm 20\%$  on magnetic encoders.

Phase ( $\phi$ ): the numbers of electrical degrees between the center of the high state of the channel A and the center of the high state of the channel B. This value is nominally 90°e for a quadrature output.

Phase Error ( $\Delta\phi$ ): the deviation of the phase from its ideal value. Typical value is max  $\pm 30^\circ e$  on optical encoders or  $\pm 40^\circ e$  on magnetic encoders.

Index length (°e): Index is aligned on the channel A and its length can be 180 °e or 90 °e (called A&B)

The incremental encoder usually provides two types of squared waves, out-of-phase of 90° electrical degrees, which are usually called channel A and B. Channel A gives information only about the rotation speed (number of pulses in a certain unit of time), while channel B provides data regarding the direction of rotation, according to the sequence produced by the two signals. The resolution can be multiply by two or four reading non only rising edges but also falling edges of A and B signals. With this method, for example, an encoder with physically 1000 pulses per revolutions can generate 2000 or 4000 pulses per revolution. Another signal, called Zero (Z or Index) channel, is also available; it gives the absolute “zero” position of the encoder shaft and is used as a reference point.

Number of encoder pulses is determined from angular or linear resolution needed. For linear applications a calculation is required to convert linear movements into rotary.

$$\text{Encoder Resolution (ppr)} = \frac{\text{Circumference}}{\text{Accuracy}}$$

Encoder max pulse frequency can be considered according to the speed and the encoder resolution.

$$\text{Frequency} = \frac{\text{rpm} \times \text{resolution (ppr)}}{60}$$

There are other encoders that integrate additional electrical output signals called incremental encoders with integrated commutation signals, normally used as motor feedback. These additional signals (called U, V, W) simulate the commutation (Hall) signals, which are usually employed in brushless motors and are usually generated by integrated magnetic sensors.

In Eltra's encoders commutation signals are optically generated and are represented as 3 squared waves, shifted by 120° electrical degrees (see below table about the relation between motor poles and pulse degrees). These signals are used by the drive to generate the correct motor supply phases sequences.

These commutation signals can be repeated many times within one mechanical revolution, since they depend directly on the number of poles of the motor.

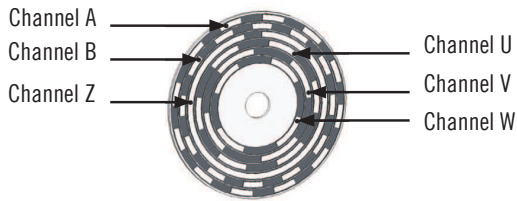

Example of 6 channels commutation encoder codewheel

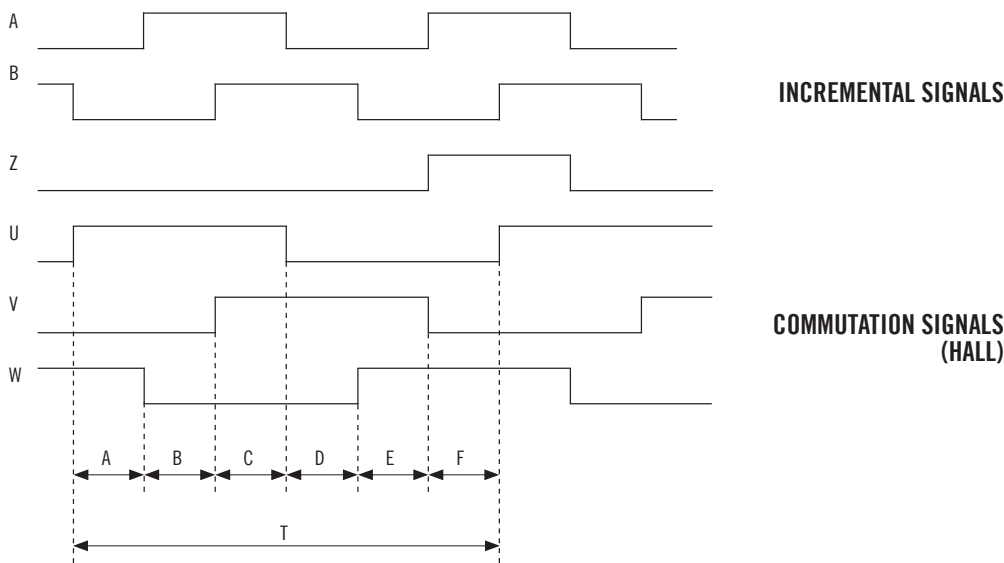

INCREMENTAL SIGNALS

COMMUTATION SIGNALS (HALL)

MOTOR POLES	A / B / C / D / E / F	T
4	30° ±1,5°	180°
6	20° ±1,5°	120°
8	15° ±1,5°	90°

A leads B clockwise rotation (shaft view)



The absolute encoder provides a unique digital code for each angle position of the shaft, storing the value of the current position and, therefore, preventing the loss of the information in case of restarting the system or of a power-loss.

The absolute encoder could be of two types:

- **Singleturn**
- **Multiturn**

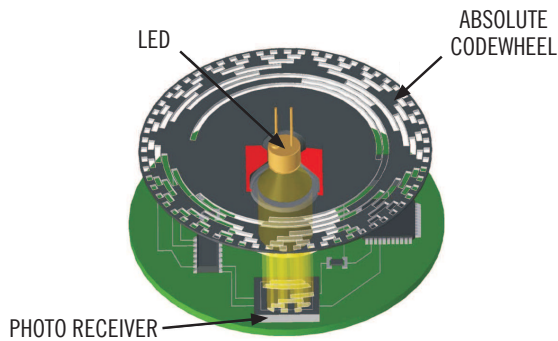

The singleturn absolute encoder allows a precise encoding of the angular position of the shaft, to which the encoder is coupled to, even if the power goes off. Therefore, each single degree position is converted into a specific code (Gray or binary) proportionally to the number of bit.

The multiturn absolute encoder allows a higher number of applications, representing a very interesting extension of the encoders' action field. Besides the angular tracking of the singleturn system, the multiturn stores also the counting of number of revolutions made.

## GRAY OR BINARY CODE

Absolute encoders are so defined since they maintain the absolute position value also after an interruption or a power-loss, so it's essential that all data referring to the position should be always available. For this purpose binary codes are employed, set by the pattern of clear and opaque segments placed crosswise or lengthwise on the disc, in relation to the direction of the movement.

## BINARY CODE

The natural binary code presents the disadvantage to have more binary digits changing between two consecutive positions. Because of mechanical tolerances, bounces or noise, it could happen that the commutation signals do not switch all at the same time when the state changes, causing intermediate situations that could produce errors in the calculation of the position.

To avoid this inconvenient and, therefore, to avoid errors in the output code, an output sync signal (STROBE) is used.

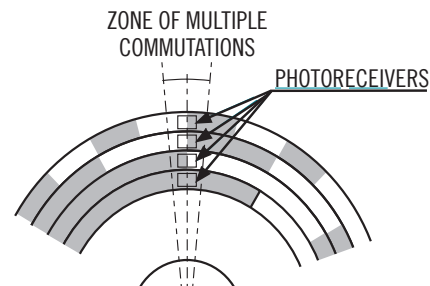

## GRAY CODE

In Gray code a single binary digit changes between consecutive steps; the code tracks are read crosswise, with respect to the direction of movement, avoiding encoding errors caused by bit changing in contiguous positions.

DECIMAL	BINARY	GRAY
0	0000	0000
1	0001	0001
2	0010	0011
3	0011	0010
4	0100	0110
5	0101	0111
6	0110	0101
7	0111	0100
8	1000	1100
9	1001	1101
10	1010	1111
11	1011	1110
12	1100	1010
13	1101	1011
14	1110	1001
15	1111	1000

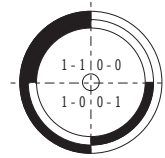

2 Bit optical disc with binary code

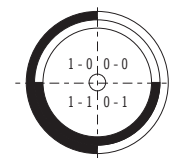

2 Bit optical disc with gray code

Gray code can be converted to binary with a simple combinatory circuit (XOR).

## THE GRAY EXCESS CODE

However, when the number of defined position is not a power of 2, even with the Gray code more than one bit can change simultaneously between the last and the first code value.

For example in a 12 ppr absolute encoder, the code should be as the one shown in the table below. It is clear that between the positions “11” and “0” 3 bit simultaneous change may involve into reading errors.

POSITION	GRAY
0	0000
1	0001
2	0011
3	0010
4	0110
5	0111
6	0101
7	0100
8	1100
9	1101
10	1111
11	1110
0	0000

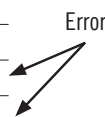

The Gray excess code is used to maintain the typical one-bit variation specificity by making the 0 position corresponding to the N value. The N is a number that subtracted from the Gray code converted into binary provides the exact position value.

The formula to calculate the N value is:

$$N = (2^n - IMP) / 2$$

Where : IMP is the number of PPR  
 $2^n$  is the power of 2 multiple immediately higher than IMP

In our example N will be:

$$N = (2^4 - 12) / 2 = (16-12) / 2 = 2$$

## NPN / NPN OPEN COLLECTOR

It is composed by an NPN transistor and a pull-up resistor used to match the output voltage to the power supply when the transistor is off (also called "sink output"). Output performances are limited by cable length,

signals frequency and load.

On the open collector variant there's no pull-up resistor so it is possible to have signals with different voltages.

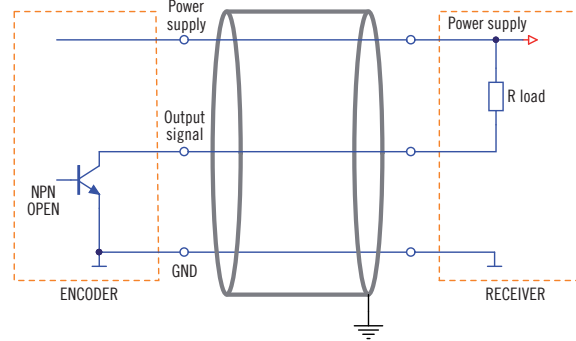
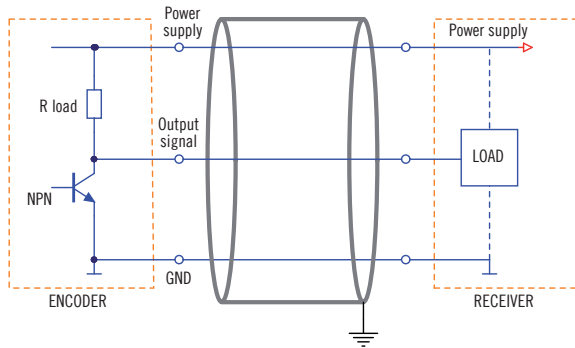

## PNP / PNP OPEN COLLECTOR

Main difference is the transistor, which is a PNP type (also called "source output"). The resistor, if present, is a pull-down one. It has same limitations as NPN in terms on cable length, frequency and load.

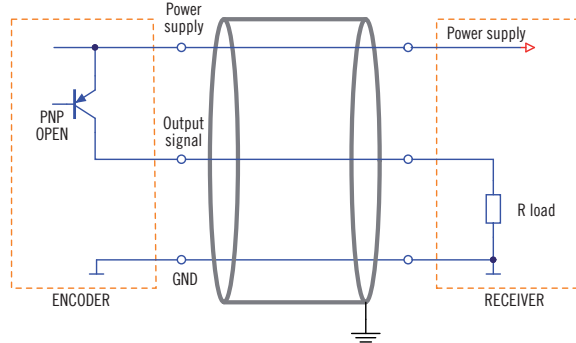
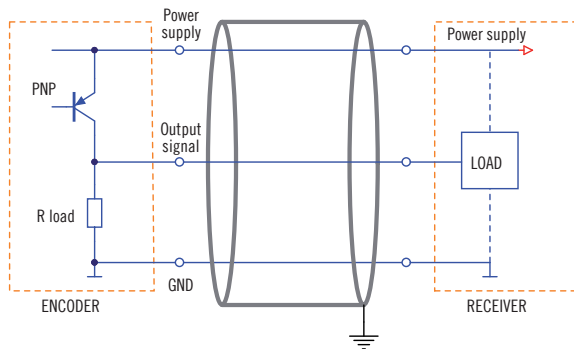

## PUSH-PULL

In NPN or PNP frequency performances are limited by the resistor, which has a much higher impedance than a transistor. To overcome this issue, push-pull electronic uses a complementary transistor, so the impedance is lower for commutation to positive and to zero.

This solution increases frequency performances allowing longer cable connections and an optimal data transmission even at high working speed. Saturation signals are low but sometimes higher than in NPN and PNP electronics. PUSH-PULL electronics can be use indifferently instead of NPN or PNP.

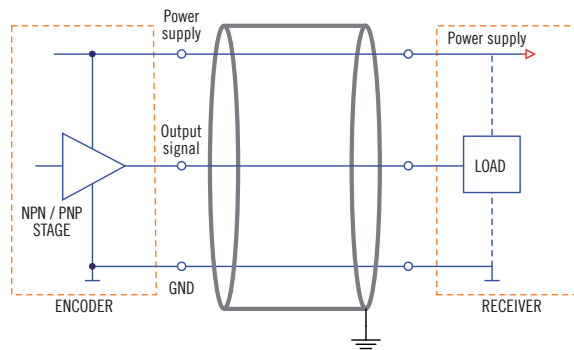

## LINE DRIVER

LINE DRIVER is used when operating environments are particularly exposed to electrical disturbances or when the encoder is quite far from the receiver system. Data transmitter and receiver work on two complementary channels so disturbances are limited (cross talk).

These interferences are known as “common mode disturbances” as their generation is due to a common point which is 0 V.

Instead, in LINE DRIVER transmitted and received signals are in “differential way” so differences between complementary channels are used and common mode signal are eliminated by the receiver.

This type of transmission is available both on +5 V DC (called RS-422) and +30 V DC models.

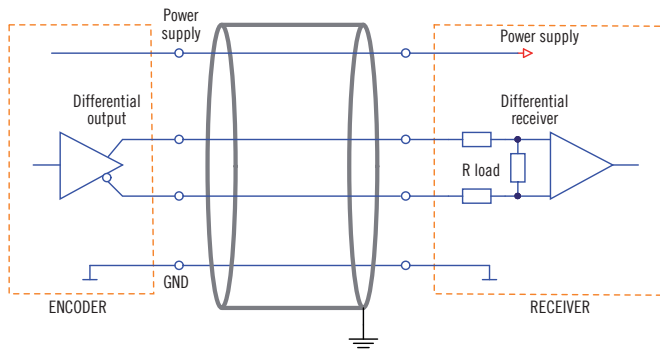

## OUTPUT STAGE PROTECTION

A highly integrated ASIC is used to protect outputs from short circuits. This solution is based on an active sensor which controls instantly the temperature reached by the element to be protected.

Moreover, it ensures a constant protection against repetitive and permanent short circuits, that is why it is strongly suggested for heavy duty applications or harsh environments. It is available for LINE-DRIVER and PUSH-PULL electronics.

## ANALOGUE INTERFACE

Analogue interface provides position by current or voltage signals. It can be used as potentiometer replacement.

Voltage range goes from 0 ... 5 V to 0 ... 10 V and current range goes from 0 ... 20 mA to 4 ... 20 mA according to industry standard interfaces.

### Current output

4 wire sink

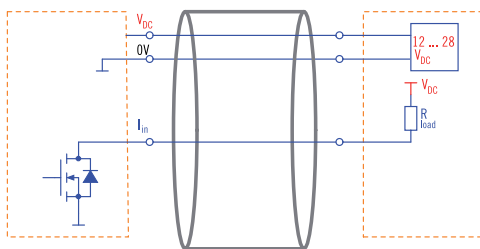

3 wire sink

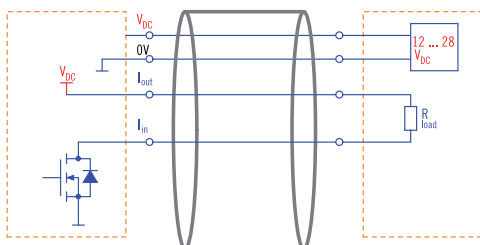

where  $R_{LOAD\ max} = (V_{DC} - 2) / 0.02$

### Voltage output

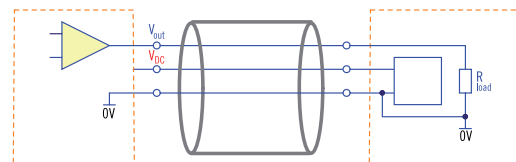

where  $R_{LOAD\ min} = 1\ k\Omega$

## BIT PARALLEL INTERFACE

The parallel output is the standard interface for singleturn and multiturn absolute encoders. These encoders provide the data output regarding the position in a “bit by bit” encoding (according to Gray or binary standards), according to the resolution of the device; parallel transmission requires indeed a wire for each bit, therefore for a higher resolution of the device

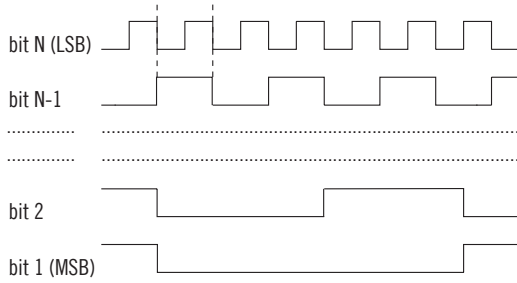

Binary bit parallel output

there will be a higher complexity of the wiring.

To reduce the number of wires, other forms of data transmission like the SSI serial interface or field bus protocols (PROFIBUS or PROFINET) have been implemented.

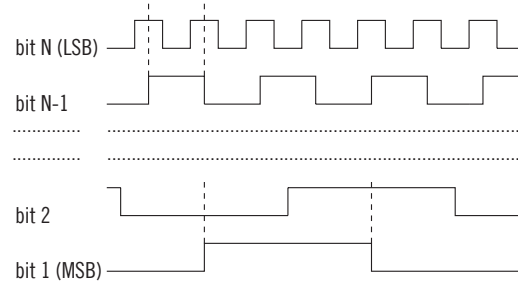

Gray bit parallel output

## SSI INTERFACE

The continuous evolution of the automation field implies a growing request for precision in measurement devices and, therefore, also in absolute encoders. To satisfy this demand, absolute encoders have been designed with always higher resolution, which means an increasing number of bit and, as a consequence, also of wires.

The Synchronous Serial Interface (SSI) was created to solve these setbacks, in order to contain installation costs and simplify the wiring. This interface transmits data in a serial mode by using only two signals (CLOCK and DATA), independently from the number of bit of the encoder.

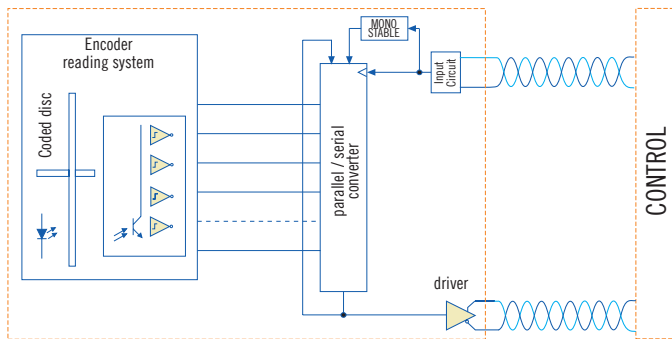

The position data is obtained by the encoder reading system and continuously transmitted to a parallel/serial converter (based by a “shift register” with parallel loading). When the mono-stable circuit is activated by a clock signal transition, the data is stored and transmitted to the output synchronized with the clock signal.

CLOCK and DATA signals are transmitted differentially (RS422) to enhance immunity from interference and to allow longer transmission distances.

When quiescent, CLOCK and DATA signals have a high logical level and the monostable circuit is disabled.

1. On the first CLOCK falling edge the monostable is activated and parallel value at the P/S converter input is stored into the shift register.
2. On the next CLOCK rising edge Most Significant Bit (MSB) is transferred into the DATA signal output.
3. On the next CLOCK falling edge (when the signal is stable) the controller acquires value from DATA signal and monostable is re-activated.
4. On each further CLOCK rising edge following bit up to the least significant one are copied in the DATA signal output and then acquired by the controller on falling edge.
5. At the end of the CLOCK pulse sequence, when the external control has also acquired the value of the Least Significant Bit (LSB), the CLOCK pulse sequence stops and therefore the monostable is no longer re-activated.
6. Once the mono-stable time ( $T_m$ ) has passed, the DATA signal returns to a high logical level and monostable disables itself.

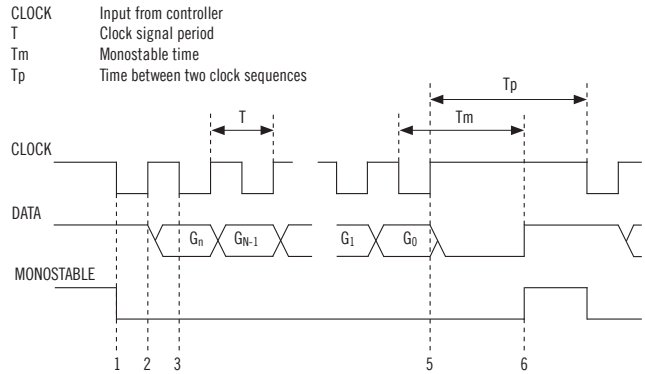

The frame length of the transmitted data depends only on the encoder type (singleturn or multiturn) and not on the resolution. In fact, the standard frame length for a singleturn encoder is 13 bit, while for a multiturn one is 25 bit.

27 bit (14 bit for revolutions + 13 bit for singleturn) and 32 bit (19 bit for revolutions + 13 bit for singleturn).

Frame alignment is on the center as shown on below table:

With multiturn encoder with number of revolutions > 4096 frame length is

$n$  = number of bit per revolution

$T$  = number of bit for revolutions  $T_c$  = clock period

$T_a = \frac{T_m - T_c}{2}$   $T_m$  = monoflop time

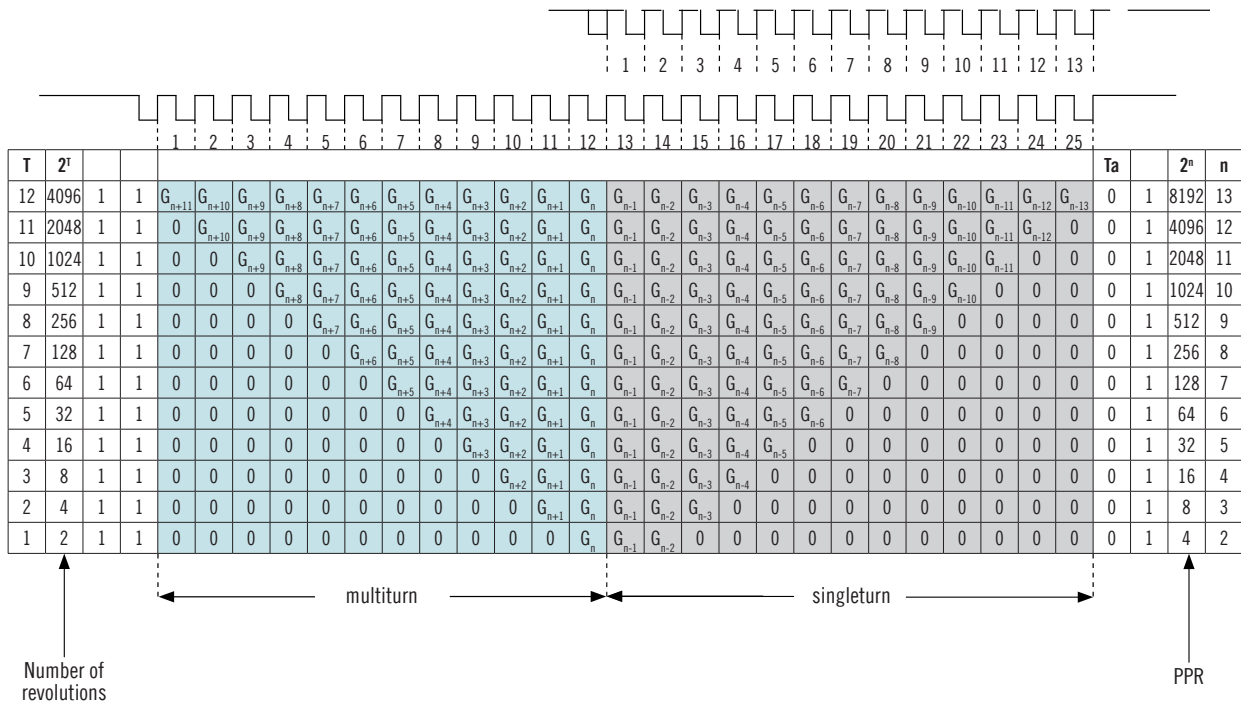

Number of revolutions

PPR



PROFIBUS (Process Field Bus) is a serial communications standard for devices connected to automation networks (field bus).

It is an open protocol defined by the DIN 19245 that became European standard as EN 50170 volume 2.

PROFIBUS is promoted by Siemens and is widely diffused all across Europe. Thanks to the definition of three different communication profiles (DP, FMS and PA), this field bus is suitable for many requirements in automation system. Starting with applications requiring a high cyclical exchange speed of

a reduced number of bit (PROFIBUS DP), up to the management of complex communications between “intelligent” devices (PROFIBUS FMS) or tasks strictly related to automation process (PROFIBUS PA).

Hereinafter the attention will be focused on the DP version (decentralized periphery), which is the standard solution to manage devices by a bus. These devices usually are: I/O modules, sensors/transducers or actuators on a low level in automation systems.

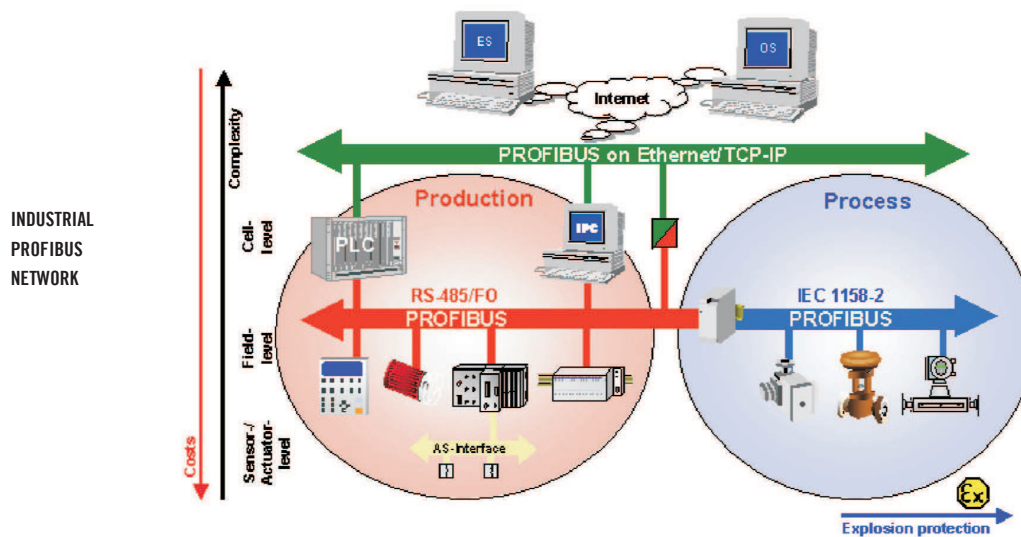

**NETWORK TOPOLOGY:** It is a common bus structure (closed on both sides) where up to 126 devices can be connected at the same time. If the physical support is an RS485 interface, up to 32 nodes can be inserted without using signal repeaters/re-generators.

**HARDWARE LEVEL:** In addition to the RS485 differential serial technology transmission, an optical fiber connection can be used. In any event, DP and FMS devices can co-exist in the same network. They share the same hardware interface communication (they are the same levels 1 and 2 of the ISO/OSI stack). The established standard requires an extremely accurate communication speed between 9.6 kBaud (min) and 12 kBaud (max).

**DEVICES PRESENT IN THE NETWORK:** It is possible to divide the devices into three classes: class 1 Master DP (DPM1), class 2 Master DP (DPM2) and

Slave. The class 1 includes all the devices periodically exchanging information with distributed peripheral (they can directly manage the I/O network data with the other nodes, mainly slaves). The class 2 masters are designated to configure and to monitor network status and devices connected to it. Slaves have the task of directly exchanging information with the external world in both directions (in and out). Typical examples of slaves are: digital I/O, encoders, drivers, valves, different types of transducers, etc.

**BUS ACCESS METHODS:** Two configurations are available in a bus with single or multi master operating ways: the ‘Token Passing’ one, for exchanging information about network management among possible available masters, and the well known ‘polling interrogation’ for the master-slave communication.

The main characteristics implemented in the PROFIBUS DP protocol are as follows:

**Periodic data exchange:** after the slave initialization step, every master is configured in order to exchange a maximum of 244 input bytes and 244 output bytes with every slave. The effective data exchange rate is based on the selected BaudRate, on the nodes present in the network and on the specific bus settings. Considering the maximum data exchange rate of 12 Mbaud, the PROFIBUS DP is one of the fastest field buses.

**Synchronization:** command controls are available (they are sent by the master in multicast). This gives the possibility to create a synchronous acquisitions through a slave, a group or all the slaves (Freeze Mode). Outputs sent to the slave have similar behavior. (Sync Mode).

**Parameterization and configuration security:** After a preset period of time - if the communication between the master/s and the slave/s is not repeated - the system goes into a safe status.

**Diagnostic functions:** each slave can require to the master to be set up for reading its own diagnostic. In such way any possible problem occurring in the slave can be easily localized. The diagnostic can contain up to 244 bytes of information. Among them, the first six are mandatory for each DP slave.

**Dynamic slave management:** there is the possibility to activate or deactivate slaves present in the network. Moreover, it is possible to change by the bus slaves addresses that make possible this function.

**Easy network configuration:** main characteristics of each device present in the network are listed in the form of a GSD file complying to Profibus specifications. This simplify the set up and the configuration of the device by a graphic tools suitable for the purpose, such as the Siemens COM PROFIBUS software. As mentioned, the master-slave exchange data takes place periodically depending on the topology of the network and on the number of nodes present. However, before this step the slave has to be successfully parameterized and configured.

**Parameter setting:** the master sends to the slave a series of parameters necessary to specify its operation. The standard requires 7 bytes containing the mandatory information for the slave. Additional data can start from the eighth byte in the DU field (Data Unit, for more information see the Profibus DP) up to a maximum of 244 bytes for the communication frame.

**Configuration:** This step starts when the master has successfully set slave's parameters. During this step the master specifies the number and type of data, or better, the number of bytes to be exchanged with the slave both for incoming and outgoing information. This data is also present in the DU field of the communication frame: if the slave accepts the configuration, it can periodically exchange with the master.

**Periodic exchange:** The master specifies within the DU field frame the necessary information and the slave sends requested data within the reply frame. During periodic exchange, the slave may advise the master that a new diagnostic data is ready and then it asks to the master if it prefers reading this information in the next polling instead of the input data coming from the peripheral.

As already mentioned, the master-slave data exchange is periodic and essentially depends on the network topology and on the present node number. However, before starting the data exchange, it is necessary that slave parameter settings and slave configuration have been successfully completed. More details are as follows:

**Parameter setting:** during this step the master sends to the slave a series of operating parameters necessary for specifying its operation. The standard requires 7 bytes containing the mandatory information for the slave. Additional data can start from the eighth byte in the DU field (Data Unit, for more information see the Profibus DP) up to a maximum up to a maximum of 244 bytes.

**Configuration:** when the master successfully set slave parameters, the configuration process starts. Then, the master specifies the number and type of data represented from the incoming and outgoing bytes number which has to be exchanged with the slave. This data is also present in DU field; if the slave accepts the configurations, it will begin to periodically exchange data with the master.

**Periodic exchange:** the master specifies within the DU field frame the needed information and the slave will send requested data in the reply frame. During periodic data exchange the slave may advise the master that a new diagnostic data is ready and then it asks to the master if it prefers reading this information in the next polling instead of the input data coming from the peripheral.

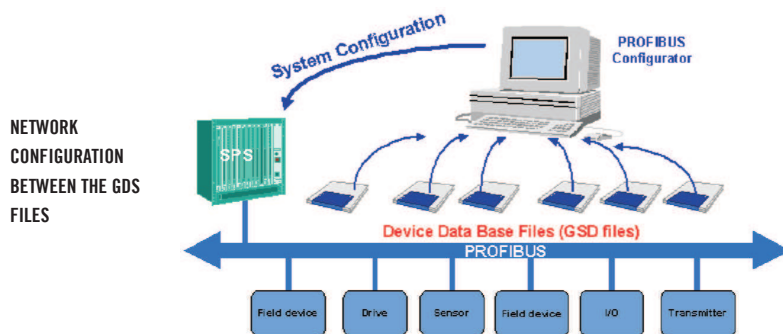

The ever-shorter innovation cycles for new products makes the continuous evolution of automation technology necessary. The use of fieldbus technology has been a significant development in the past few years. It has made possible to migrate from centralized automation systems to decentralized ones. PROFIBUS, as the global market leader, has set the benchmark here for 25 years. In today's automation technology, Ethernet and information technology (IT) are increasingly calling the shots with established standards like TCP/IP and XML.

Integrating information technology into automation opens up significantly better communication options among automation systems, extensive configuration and diagnostic possibilities, and network-wide service functionality.

These functions have been integral components of PROFINET from the outset. PROFINET is the innovative open standard for Industrial Ethernet.

PROFINET satisfies all requirements of automation technology; whether the application involves production automation, process automation, or drives (with or without functional safety), PROFINET is the first choice across the board.

As a technology that is standard in the automotive industry, widely disseminated in machine building, and well-proven in the food and packaging and logistics industries, PROFINET has found its way into all application areas.

New application areas are constantly emerging, such as marine and rail applications or even day-to-day operations, for example, in a beverage shop. And now: the new PROFenergy technology profile will improve the energy balance in production processes.

PROFINET is standardized in IEC 61158 and IEC 61784.

The ongoing further development of PROFINET offers users a long-term view for the implementation of their automation tasks.

For plant and machine manufacturers, the use of PROFINET minimizes the costs for installation, engineering, and commissioning.

For plant owners, PROFINET offers ease of plant expansion and high plant availability due to autonomously running plant units and low maintenance requirements. The mandatory certification for PROFINET devices also ensures a high quality standard.

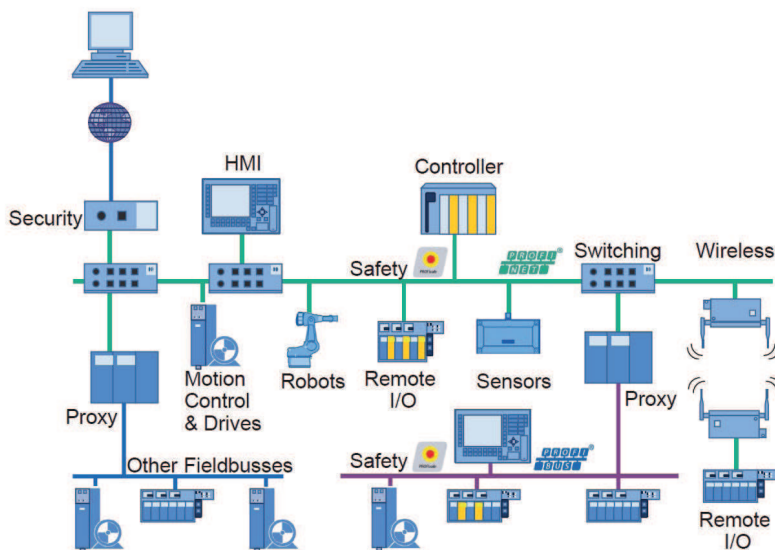

Example of plant network

The scope of functions supported by PROFINET IO is clearly divided into conformance classes ("CC").

These provide a practical summary of the various minimum properties.

There are three conformance classes that build upon one another and are oriented to typical applications (see figure).

CC-A provides basic functions for PROFINET IO with RT communication. All IT services can be used without restriction. Typical applications are found, for example, in business automation. Wireless communication is specified for this class.

CC-B extends the concept to include network diagnostics via IT mechanisms as well as topology information. The system redundancy function important for process automation is contained in an extended version of CC-B named CC-B(PA).

CC-C describes the basic functions for devices with hardware-supported bandwidth reservation and synchronization (IRT communication) and is thus the basis for isochronous applications.

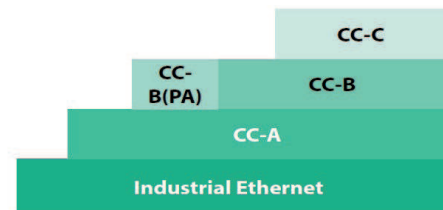

Structure of conformance classes

The conformance classes also serve as the basis for the certification and the cabling guidelines.

A detailed description of the CCs can be found in the document "The PROFINET IO Conformance Classes" [7.042].

The PROFINET concept was defined in close collaboration with end users based on standard Ethernet according to IEEE 802 in IEC 61158 and IEC 61784. Figure below lists additional specifications of the functionalities in the form of different joint profiles. These form the basis for device or

application-specific profiles. Instructions are created for the necessary planning, engineering, and commissioning steps. The basics for this form the guidelines for engineering PROFINET systems.

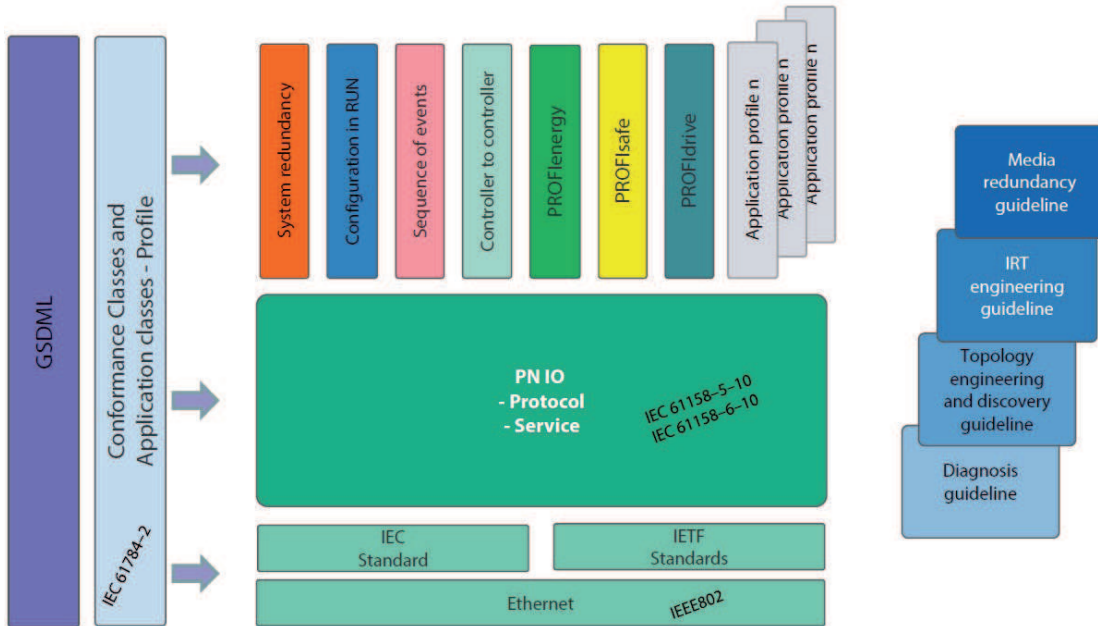

PROFINET IO follows the Provider/Consumer model for data exchange. Configuring a PROFINET IO system has the same look and feel as in PROFIBUS. The following device classes are defined for PROFINET IO (figure below):

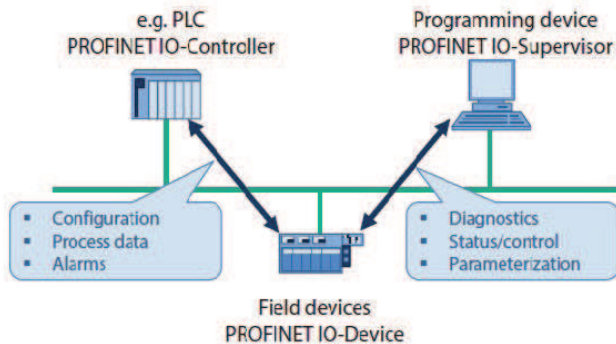

**IO Controller:** this is typically the programmable logic controller (PLC) on which the automation program runs. This is comparable to a class 1 master in PROFIBUS. The IO controller provides output data to the configured IO devices in its role as provider and is the consumer of input data of IO devices.

**IO Device:** an IO device is a distributed I/O field device that is connected to one or more IO controllers via PROFINET IO. It is comparable to the function of a slave in PROFIBUS. The IO device is the provider of input data and the consumer of output data.

**IO Supervisor:** this can be a Programming Device (PD), personal computer (PC), or human machine interface (HMI) device for commissioning or diagnostic purposes and corresponds to a class 2 master in PROFIBUS.

A plant unit contains at least one IO controller and one or more IO devices. IO supervisors are usually integrated only temporarily for commissioning or troubleshooting purposes.

According to specific electrical interface please consider output levels per table below

LEVELS							
Output circuit	NPN	NPN Open collector	PNP	PNP Open collector	Push-pull	Line driver HTL	RS422
Ordering code	N	C	R	U	P / PC	L	S / RS
Load current	20 mA	20 mA	20 mA	20 mA	20 mA	20 mA	/
Signal levels							
HIGH (min)	+V DC - 2,5 V	/	+V DC - 2,5 V	/	+V DC - 2,5 V	+V DC - 2,5 V	2,5 V
LOW (max)	0,5 V	0,5 V	0,5 V	0,5 V	0,5 V	0,5 V	0,5 V
Note		Ext. power supply max +30 V DC		Ext. power supply max +30 V DC			
Reverse polarity power supply protection	see product datasheet						
Short circuit proof outputs	see product datasheet						

## ENCODER CABLE LENGTH

Based on the power supply, electrical interface and output frequency maximum cable length are as below tables:

INCREMENTAL ENCODERS			
Power supply (+ V DC)	Electrical interface	Frequency (kHz)	Max cable length (m)
5V	RS-422	50	300
5V	RS-422	100	200
5/30V - 5/28V - 8/24V	Line driver HTL	50	80
5/30V - 5/28V - 8/24V	Line driver HTL	100	40
5/30V - 5/28V - 8/24V	Push-pull	50	60
5/30V - 5/28V - 8/24V	Push-pull	100	30

ABSOLUTE ENCODERS			
Power supply (+ V DC)	Electrical interface	Frequency (kHz)	Max cable length (m)
8/28V - 8/30V	Push pull Bit parallel	25	100
5V - 8/28V - 8/30V	SSI	100	300
5V - 8/28V - 8/30V	SSI	200	200
5V - 8/28V - 8/30V	SSI	400	50
5V - 8/28V - 8/30V	SSI	1000	10
12/28V	Analogue (current)	-	200

System setup: ambient temperature (20°C / +68°F), load current 20 mA, Eltra AWG 24 shielded cable.

Depending on the application, maximum cable length might be shorter, particular eg: where a high level of electrical noise is present.

Please carefully select the power supply core diameter. Size should be enough to guarantee that encoder voltage levels will not go below minimum levels. Use always shielded cables, for further details or informations please directly contact our offices.

## AUXILIARY INPUTS / OUTPUTS

### INPUTS

UP/DOWN (U/D): when connected to logic HIGH encoder output will invert the counting direction. It is equivalent to rotate the encoder shaft in the opposite direction.

LATCH: when connected to logic state HIGH, it freezes the current data output. In this way, while the encoder shaft is turning, the output data does not change.

RESET: when connected to logic state HIGH it sets the output position to zero.

### OUTPUTS

STROBE: available on absolute encoders with binary code. It goes to logic state HIGH when the output data is valid (all output data has been updated).

INPUT	STATE HIGH	STATE LOW
U / D	Inverts the code	No effect
LATCH	Blocks the code	No effect
RESET	Output reset	No effect

**PROPER INSTALLATION OF CABLES**

- Make sure cable shield is connected to the ground and avoid connecting it to the power ground (0 V).
- Keep the encoder cable (signal cable) sufficiently far from power lines.
- Choose the cable according to installation requirements.
- Lay the cable avoiding spirals.
- Minimum cable bending radius at least 10 times external diameter.

**CONNECTOR**

Connector type	Ref. code
JIS-C-5432 7 pins cable mount straight plug (female)	PLS-20-7 (PLT® Apex)
JIS-C-5432 10 pins cable mount straight plug (female)	SCC6A16-10S (Sam Woo Electronics)
MIL 7 pins cable mount straight plug (female)	MS3106-16S-1 (Amphenol®)
MIL 10 pins cable mount straight plug (female)	MS3106-18-1 (Amphenol®)
M23 12 pins cable mount straight plug (female)	M23 12 pins CCW (contact arrangements)
V 9 pins cable mount straight plug (female)	D-Subminiature DE-9
M 12 5 pins cable mount straight plug (female)	M12 5 pins A coded 360° totally shielded
M 12 8 pins cable mount straight plug (female)	M12 8 pins A coded 360° totally shielded
MIL 19 pins cable mount straight plug (female)	MS3116-14-19S (Amphenol®)
VB 15 pins cable mount straight plug (female)	D-Subminiature DA-15
VC 15 pins cable mount straight plug (female)	D-Subminiature DE-15 (high density)
S3 5 pins cable mount straight plug (female)	M12 5 pins B coded Profibus
MIL 32 pins cable mount straight plug (female)	62IN-16PHM21-1832S624 (Amphenol®)

**CUSTOM CABLES AND MORE ...**

- Custom cables, extensions and connector are available on demand.
- Testing on 100 % of the production.
- Anti-vibration wiring system.
- **Contact us for further informations.**

**CABLES AVAILABILITY**

N° WIRES	CEI MARKING	IEC MARKING	UL MARKING	SHIELD	INSTALLATION
5	CEI 20-22 II			FOIL	FIXED
		IEC 60332-1	UL-CSA	BRAID	FLEXIBLE
		IEC 60332-1	UL-CSA	FOIL	FIXED
	CEI 20-22 II	IEC 60332.3		BRAID	FIXED
8	CEI 20-22 II			FOIL	FIXED
	CEI 20-22 II			BRAID	FIXED
		IEC 60332-1	UL-CSA	BRAID	FLEXIBLE
		IEC 60332-1		FOIL	FIXED
	CEI 20-22 II	IEC 60332.3		BRAID	FIXED
10	CEI 20-22 II			BRAID	FIXED
12	CEI 20-22 II			FOIL	FIXED
16	CEI 20-22 II			FOIL	FIXED
32	CEI 20-22 II			FOIL	FIXED

Please directly contact our offices for non-standard cables availability

**PRECAUTIONS AGAINST ELECTROSTATIC DISCHARGES**

Be sure the metallic case of the connector is connected to the ground through a ring fixed to the screw of the connector itself. (Fig. 1)  
Connect the cable shield to the ground and to the connector case. (Fig. 2)

Fig. 1

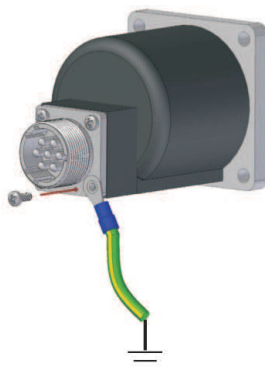

Fig. 2



For a better protection of the electronics against electrostatic discharges connect the metallic connector case to ground.

## INSTALLATION AND OPERATION PRECAUTIONS



The encoder must be used with respect to its specifications. Encoder is a pulse generator and not a safety device.



Assembling and installing personnel must be qualified and carefully follow instructions of technical manuals.



Don't expose the device to stress or impacts in order to ensure the correct working otherwise the warranty expires.



Make sure that the mechanical coupling of the encoder shaft is designed with the appropriate elastic couplings, especially in the case of excessive axial or radial movements.



Make sure that the environment of use is free of corrosive agents (acids, etc.) or substances that are not compatible with the device.



Check the ground connection of the device if it is not possible to provide additional external connection.



Before putting it in operation, verify the voltage range applicable to the device and protect it from exceeding the stated technical specifications.



Connect power supply and signals cables in order to avoid capacitive or inductive interferences that may cause malfunction of the device.



**Cable wiring must be carried out in a POWER-OFF condition.**



**For safety reason, we strongly recommend to avoid any mechanical or electrical modification. In that case, they will void the warranty.**



For storage leave the products in the original packaging. The storage location should be free of dust, dry and temperature-regulated without chemical influences or mechanical shock / vibrations.



For storage times greater than 12 months please rotate the encoder shaft every 12 months at low-speed (e.g. by hand) to allow bearing lubrication to distribute.

## MAIN PRODUCT WARRANTY TERMS

Replacements or repairs whether under the warranty or at the customer's expense must be performed in the service department of Eltra or by explicitly authorized personnel. Before sending material for repairing, you must obtain an RMA number from our sales office.

During the repair process in our service department, Eltra will be authorized to remove all parts that the customer added to the product.

Any malfunction due to a failure to observe these usage and installation precautions will lead to the warranty voiding.

Repairs will not extend the product warranty.

We also exclude compensation for any type of damage or injury due to the use, or suspension of use, of the transducer.

For any additional information, please refer to the sale terms on our website, [www.eltra.it](http://www.eltra.it), or call our office.

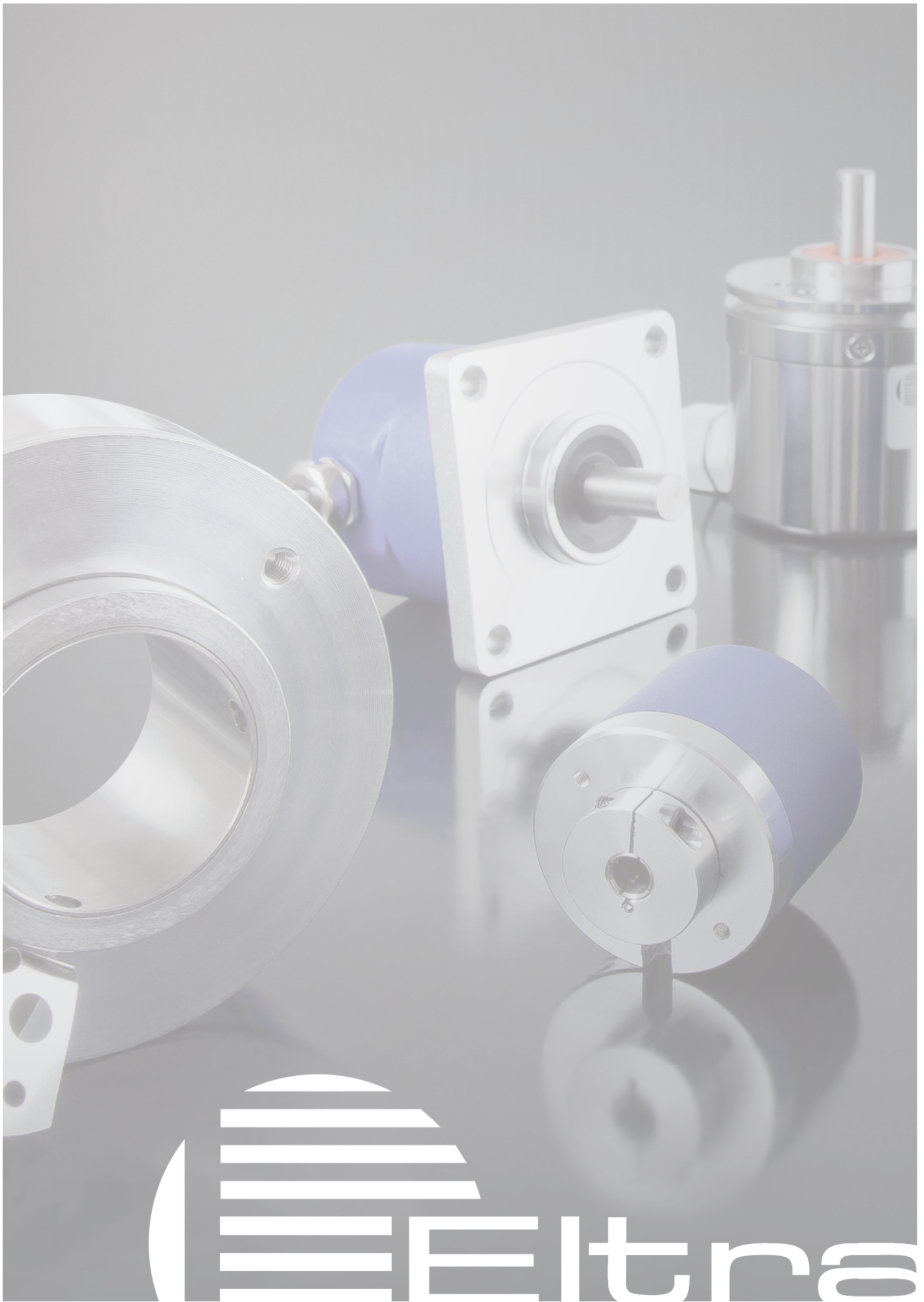

 **Filtra**